

L

LIGHT ELECTRONICS CO., LTD.

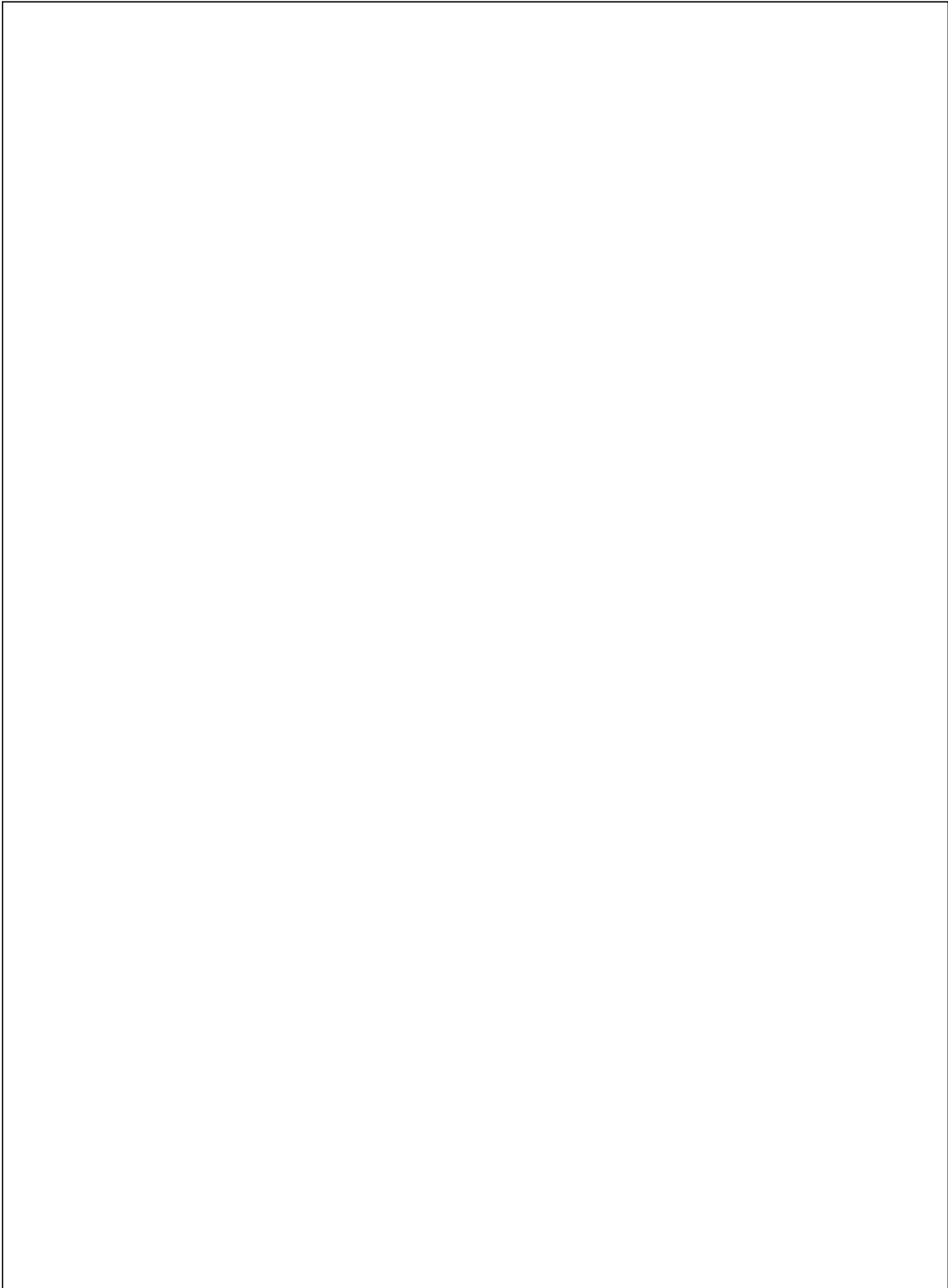



□□□□□□ □□□□□□□□ □□□□□ □□□□□□□□□□ □□□□□
(□□ □□ □□□□□□ □□□□□□ □□□□□ □□□□ □□□□□)

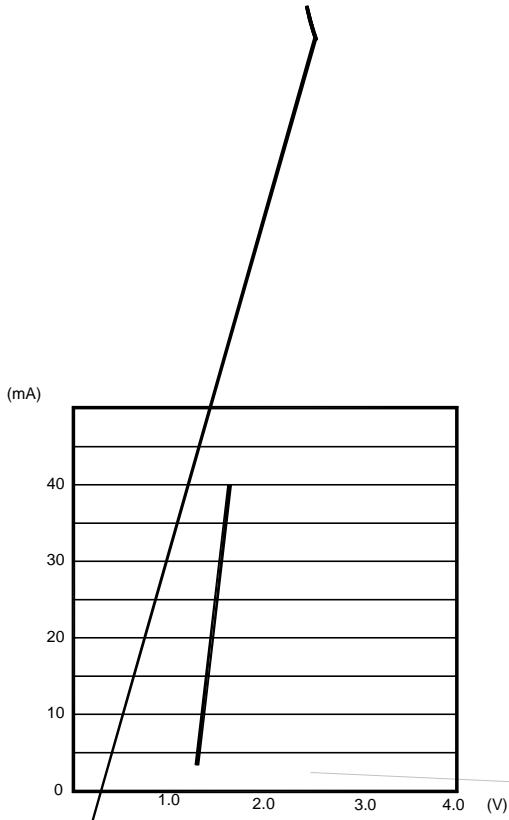

Carrier Tape Specifications

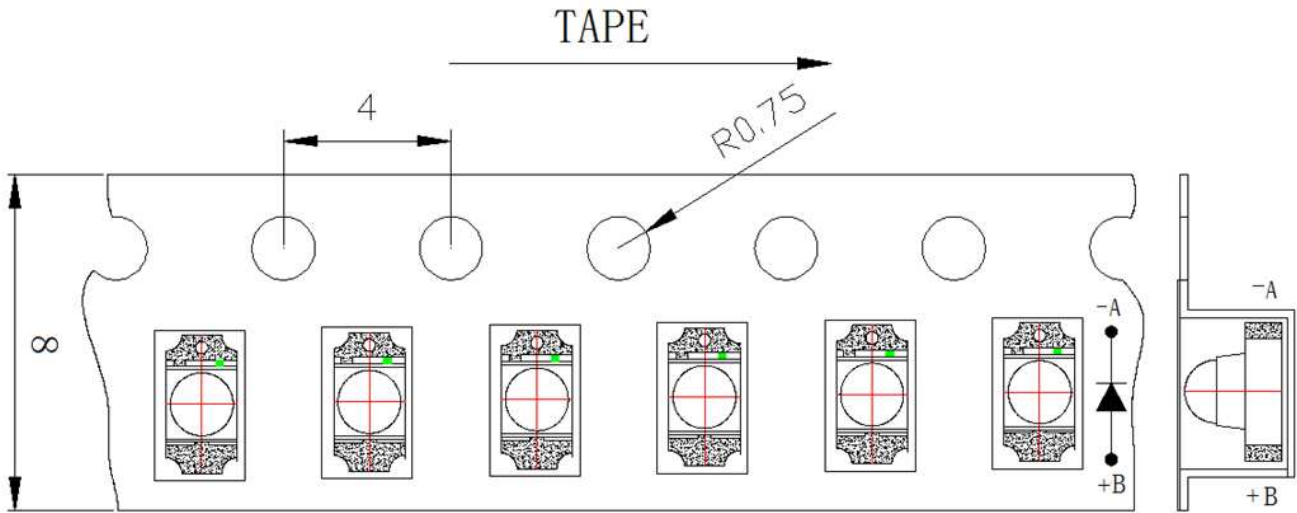

Moisture Resistant Packaging

