





--	--	--	--



LG -Q R-R009-01

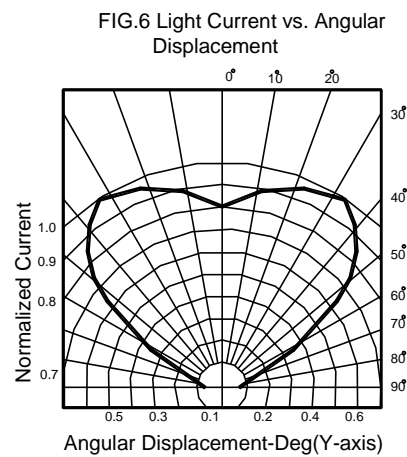
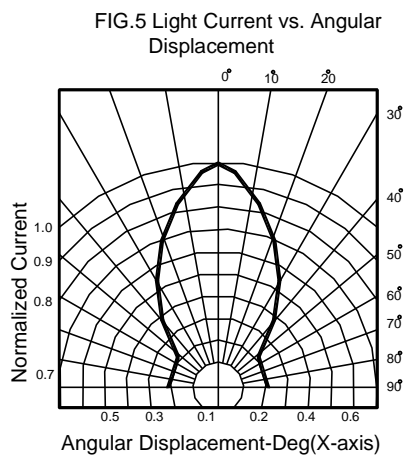
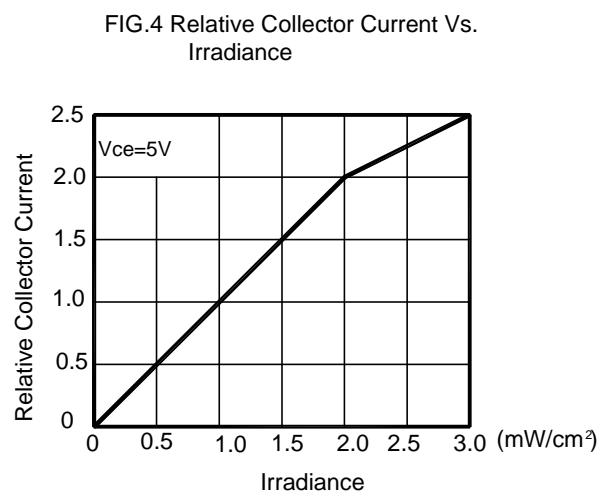
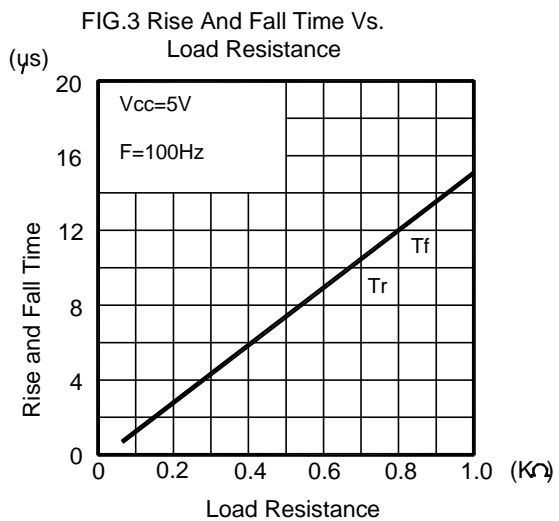
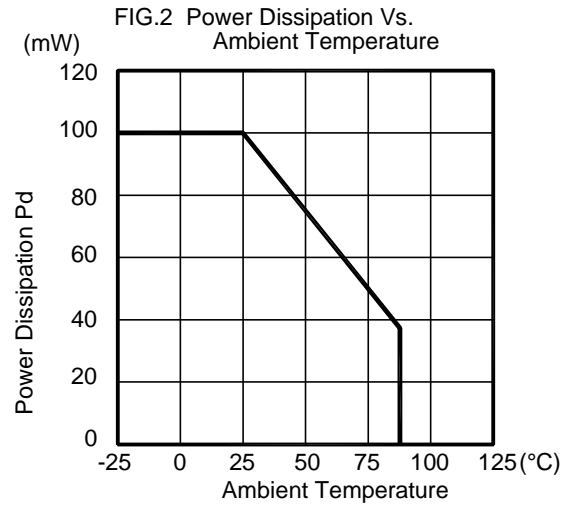
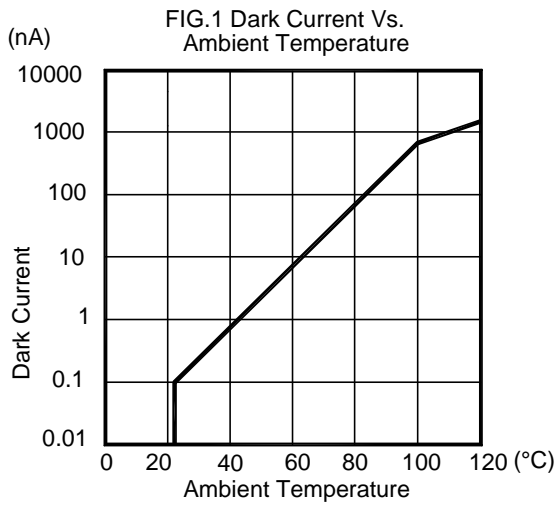

Label Explanation

LIGHT	深圳莱特光电股份有限公司 Light Electronics CO., LTD.	
TYPE NO. :	_____	
QUANTITY :	_____	
BIN :	_____	
DATE CODE :	_____	
REMARKS :	_____	

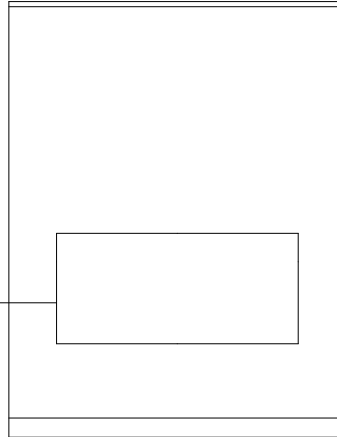

Reel Dimensions

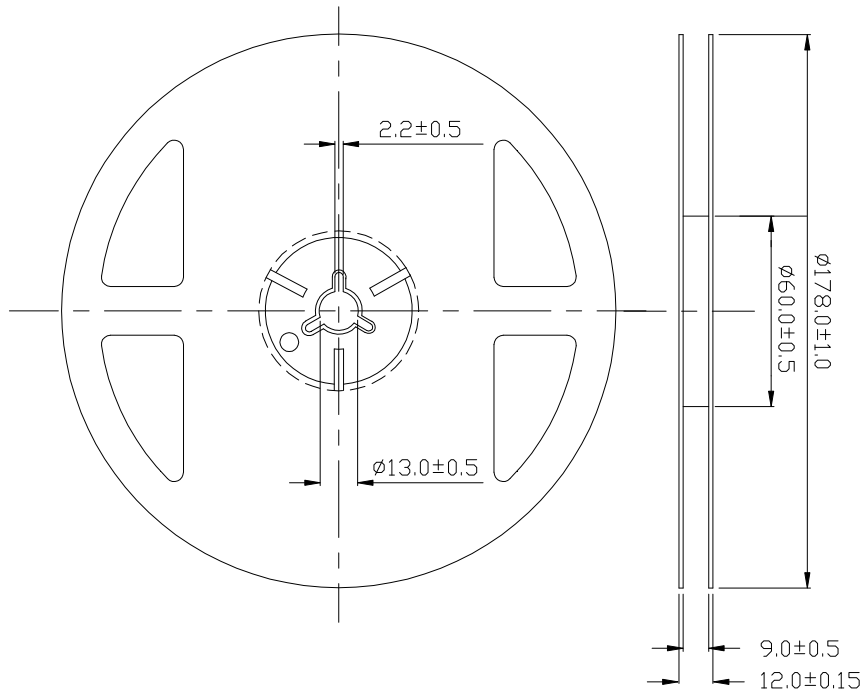

Suggest IR Reflow Condition For Lead Free

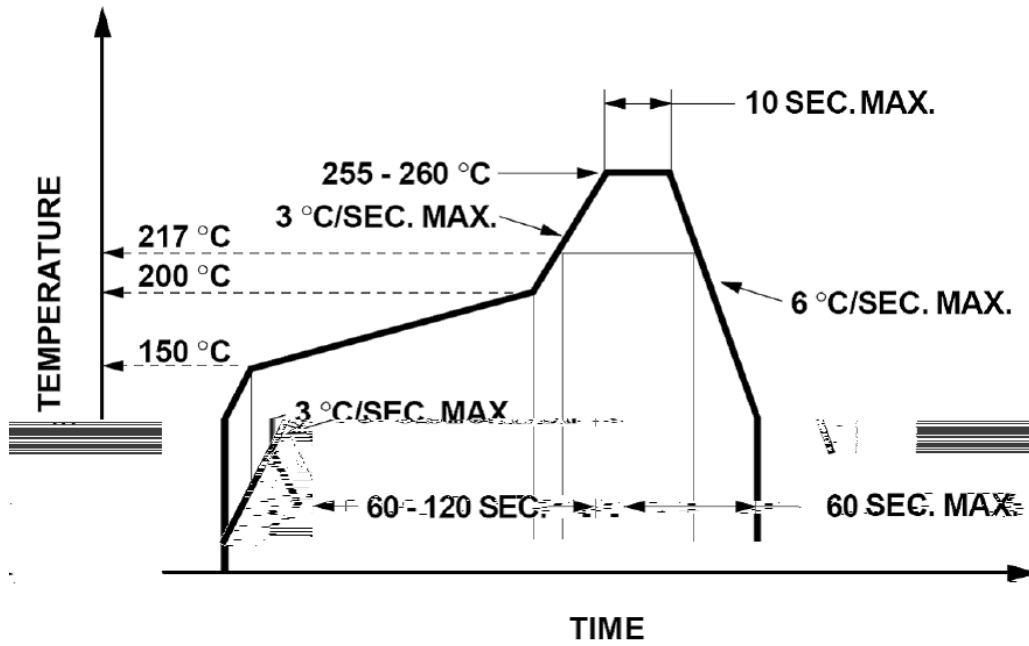

Soldering iron

°C

Repairing

