

# **SL-T3020IRC050-L268-U**

\_\_\_\_\_  
\_\_\_\_\_  
\_\_\_\_\_

## Features

## Package Dimension

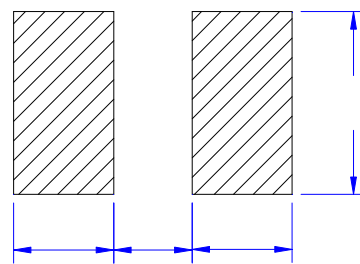
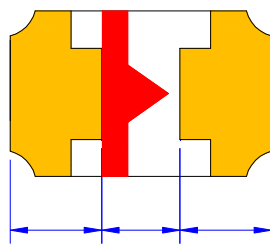
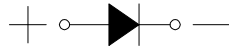
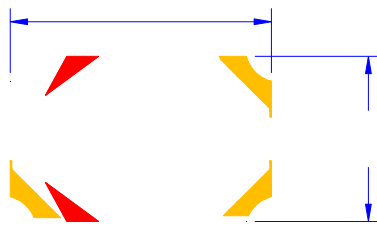

Notes:

## Absolute Maximum Ratings at Ta=25



1. Storage and operating:

2. Peak Forward Current:

Condition for is IFP pulse: Pulse Width 100 $\mu$ s and duty 1%.

3. Caution in ESD:

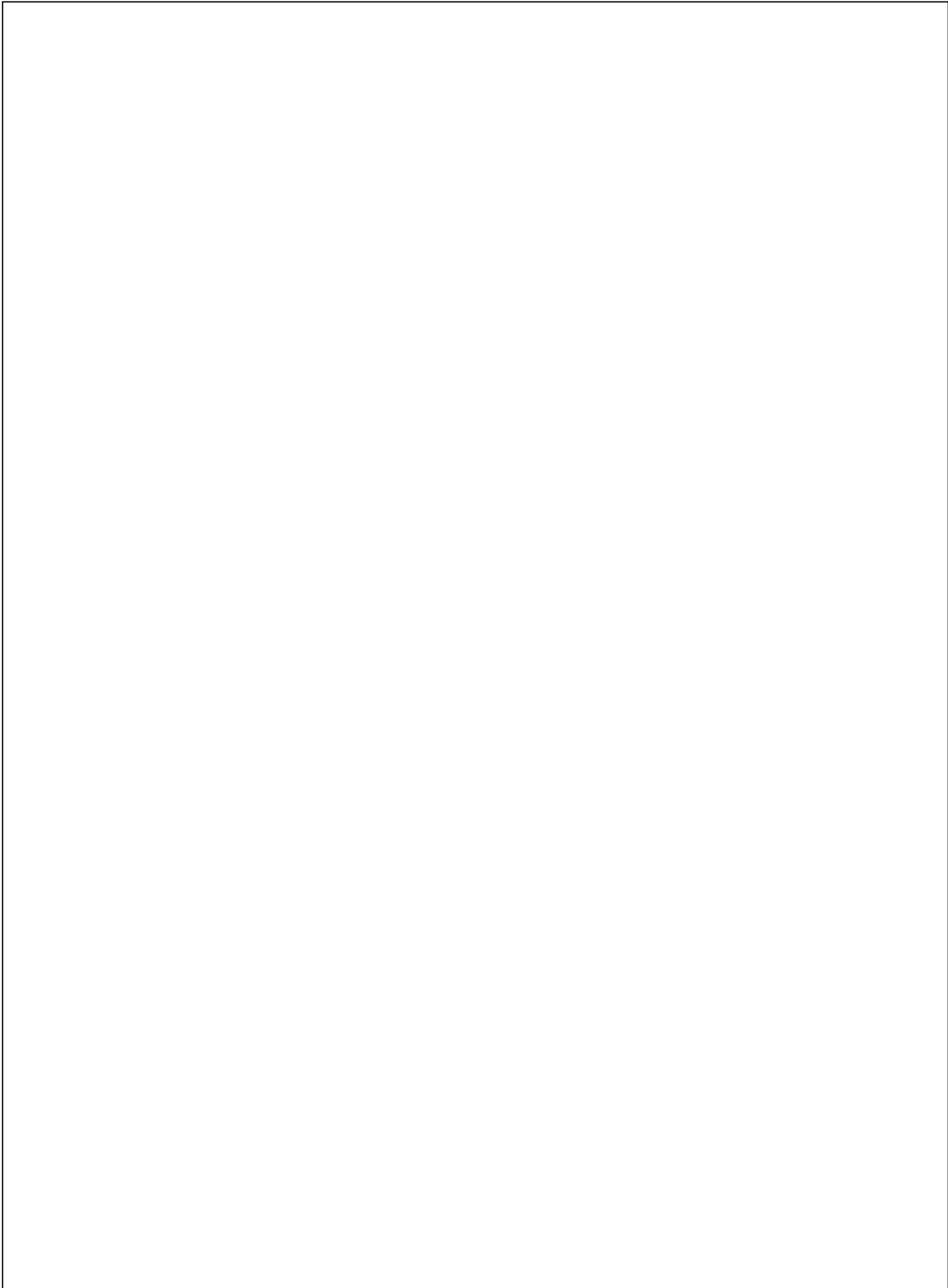



	44	53
	53	64
	64	77
	...	...

**NOTE**



Note:





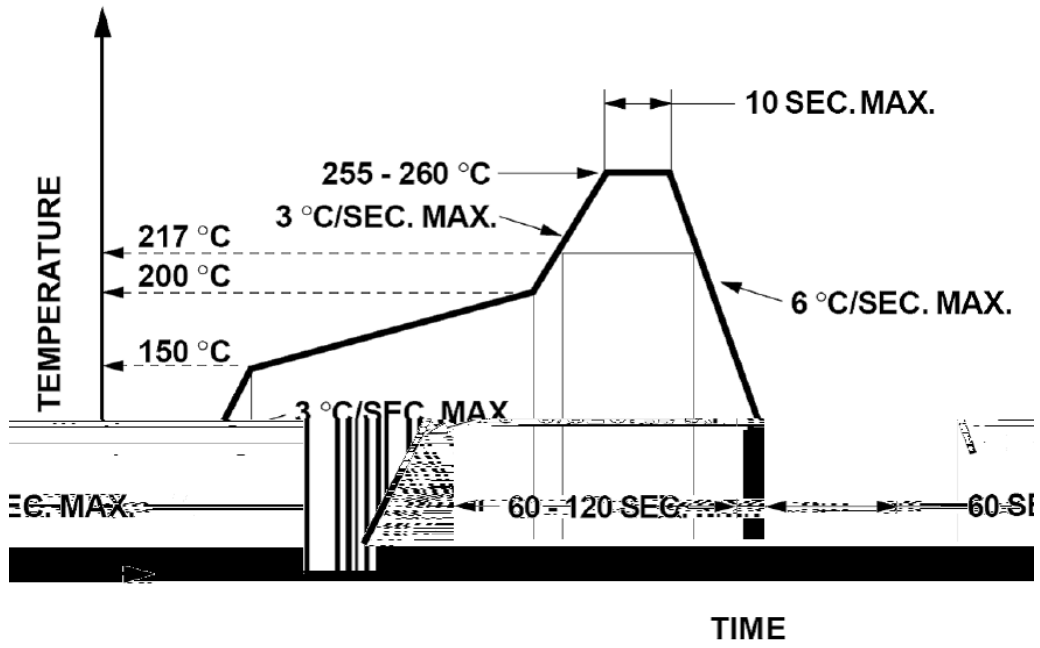

°C

