



Electrical Optical Characteristics at Ta=25

	2					
Peak Wavelength	p	---	940	---	nm	I
		---	50	---	nm	I

Note:

2

Radiant Intensity Bin Code (IF=50mA)

BIN CODE	Min. (mW/sr)	Max. (mW/sr)
31	21	26
32	26	31
33	31	37
34	37	44
35	44	53

NOTE

Label Explanation



Suggest IR Reflow Condition For Lead Free

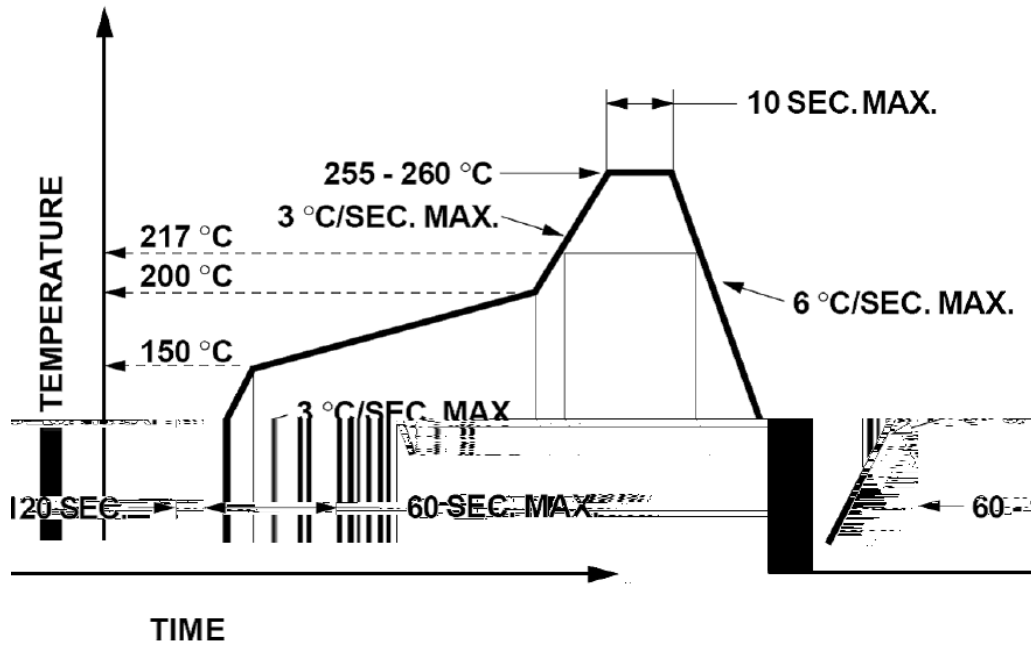

Soldering iron

°C

Repairing

