

Features

- Pb free product—RoHS compliant
- High Photo Sensitivity
- Reliable and rugged
- Long life – solid state reliability
- Sensitivity angle: 85°

Package Dimension

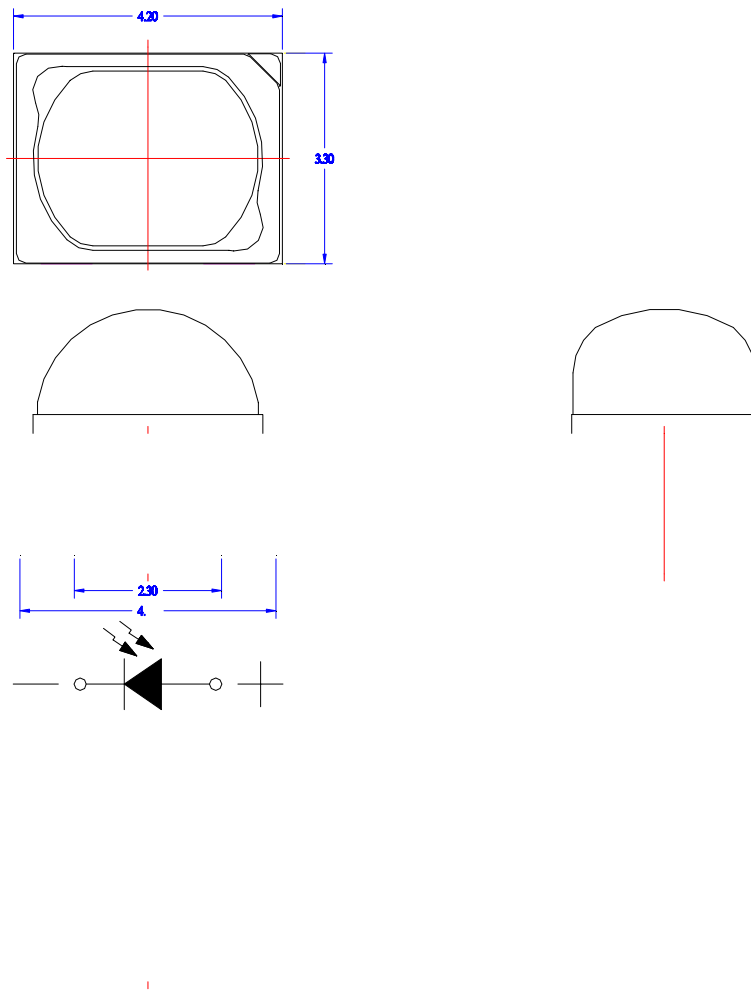

Part NO.	Chip Material	Lens Color
SL-T4232PDB020-L415	Silicon	Black

Notes:

1. All dimensions are in millimeters.
2. Tolerance is $\pm 0.10\text{mm}$ unless otherwise noted.
3. Specifications are subject to change without notice.



Typical Electrical / Optical Characteristics Curves (25 Ambient Temperature Unless Otherwise Noted)

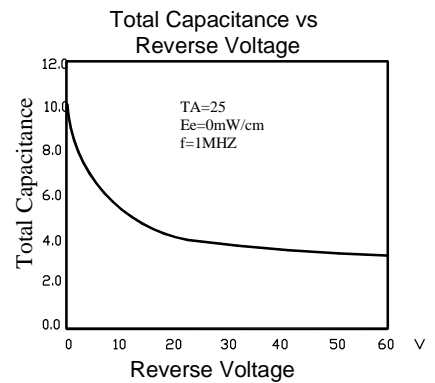
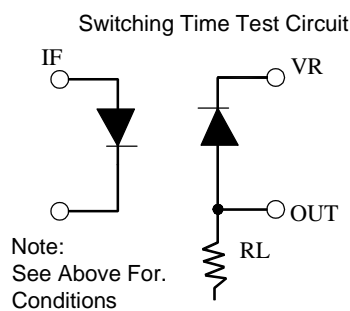
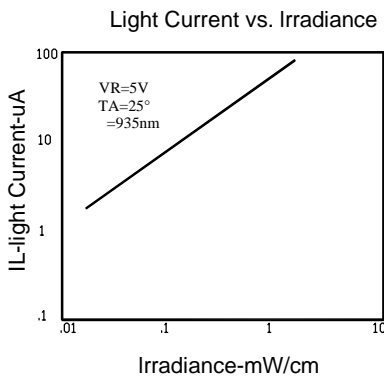
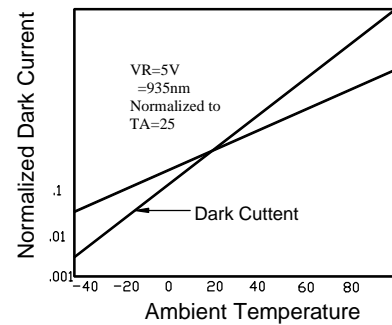
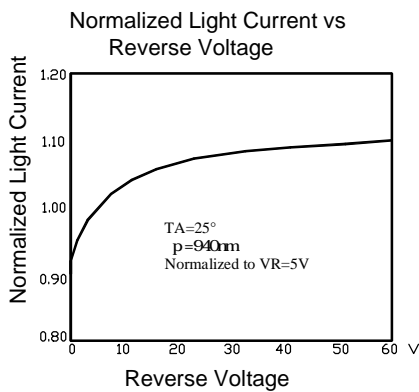
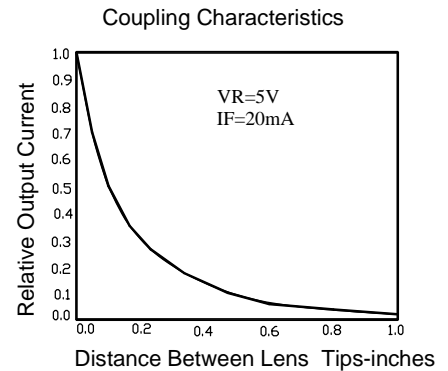
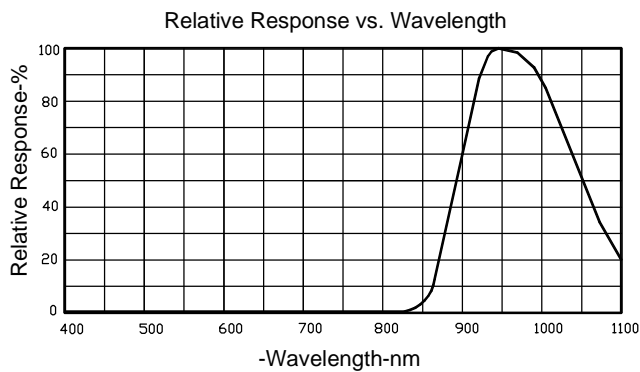

LIGHT

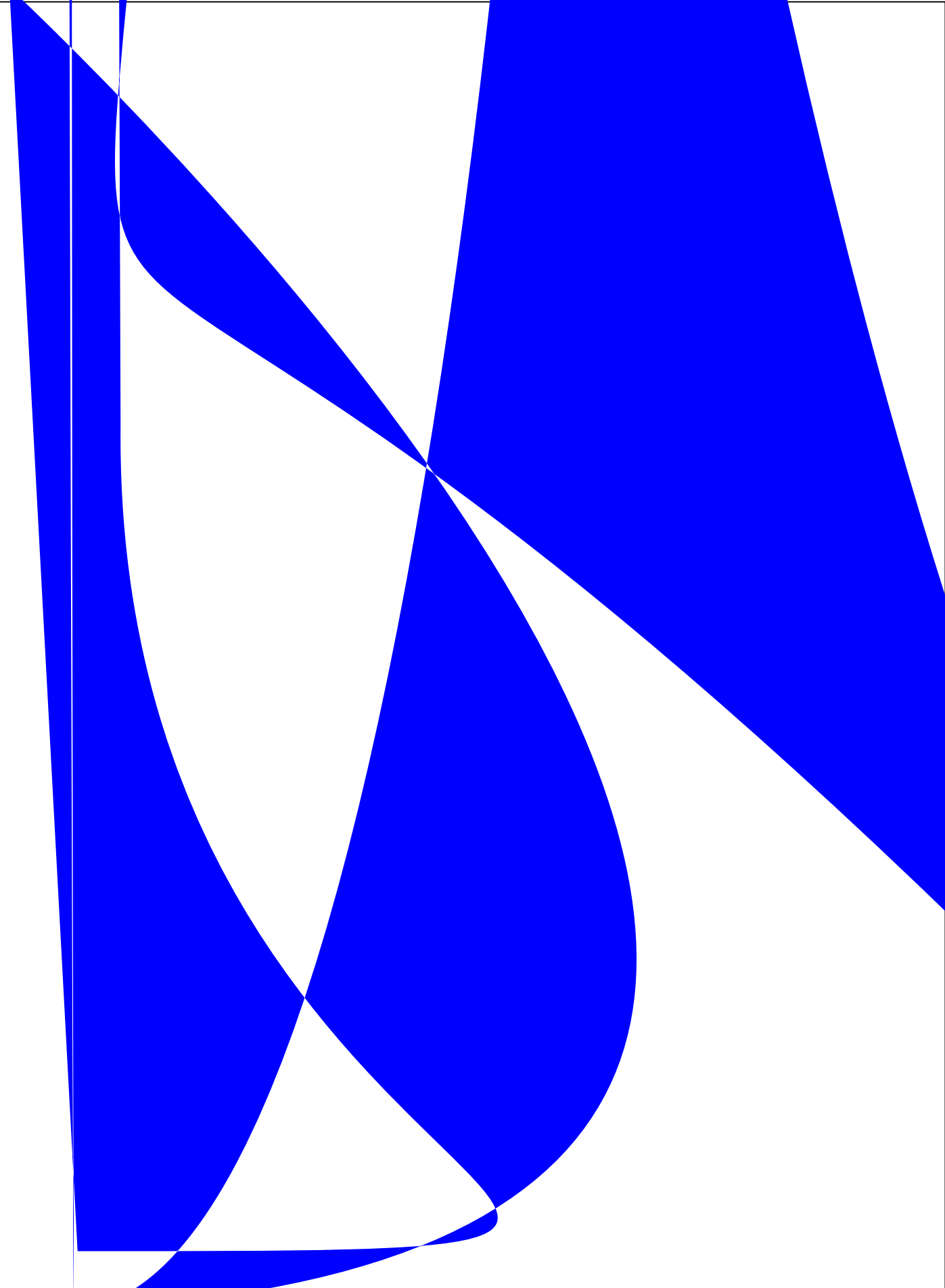

LIGHT

Part No. SL-T423

