

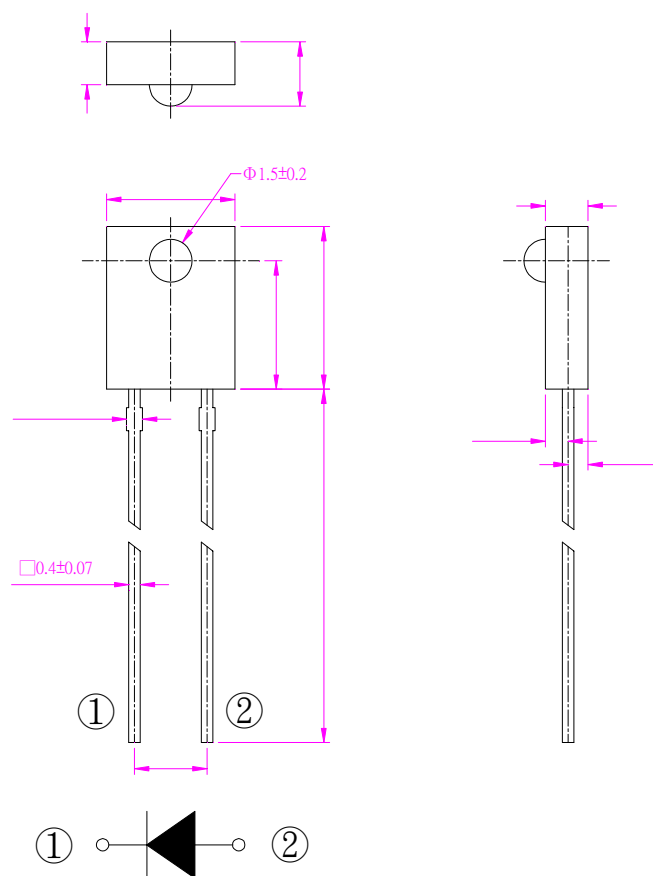

## Features

- Pb free product—RoHS compliant
- Low power consumption, High efficiency
- General purpose leads
- Reliable and rugged
- Long life – solid state reliability
- Radiant angle: 40°

## Package Dimension



Part NO.	Chip Material	Lens Color
LG-256IR2C94A-908	GaAs	Water Clear

### Notes:

1. All dimensions are in millimeters.
2. Tolerance is  $\pm 0.20$ mm unless otherwise noted.
3. Protruded resin under flange is 1.0mm max.
4. Lead spacing is measured where the leads emerge from the package.
5. Specifications are subject to change without notice.

## Absolute Maximum Ratings at Ta=25°C

Parameter	MAX.	Unit
Power Dissipation	75	mW
Continuous Forward Current	50	mA
Peak Forward Current <sup>*3</sup>	1.0	A
Reverse Voltage	5	V
Electrostatic Discharge (HBM) <sup>*4</sup>	4000	V
Operating Temperature	-40 to + 85	
Storage Temperature	-40°C to + 100°C	
Lead Soldering Temperature [2mm From Body]	260 for 3 Seconds	
Lead Soldering Temperature [5mm From Body]	260 for 5 Seconds	

### 1. Storage:

The storage ambient for the LEDs should not exceed 30°C temperature or 70% relative humidity.

It is recommended that LEDs out of their original packaging are used within three months.

For extended storage out of their original packaging, it is recommended that the LEDs be stored in a sealed container with appropriate desiccant or in desiccators with nitrogen ambient.

### 2. Precautions in handling:

When soldering, leave 2mm of minimum clearance from the resin to the soldering point.

Dipping the resin to solder must be avoided.

Correcting the soldered position after soldering must be avoided.

In soldering, do not apply any stress to the lead frame particularly when heated.

When forming a lead, make sure not to apply any stress inside the resin.

Lead forming must be done before soldering.

It is necessary to cut the lead frame at normal temperature.

### 3. Peak Forward Current:

Condition for is IFP pulse: Pulse Width 100µs and duty 1%.

### 4. Caution in ESD:

Static Electricity and surge damages the LED. It is recommend to use a wrist band or anti-electrostatic glove when handling the LED. All devices, equipment and machinery must be properly grounded.

## Electrical Optical Characteristics at Ta=25°C

Parameter	Symbol	Min.	Typ.	Max.	Unit	Test Condition
Radiant Intensity	I <sub>e</sub>	0.44	0.80	---	mW/sr	I <sub>F</sub> =5mA (Note 1,3)
Viewing Angle	2 <sub>1/2</sub>	---	40	---	Deg.	(Note 2)
Peak Wavelength	λ <sub>p</sub>	---	940	---	nm	I <sub>F</sub> =5mA
Spectral Line Half- Width		---	50	---	nm	I <sub>F</sub> =5mA
Forward Voltage	V <sub>F</sub>	---	1.2	1.5	V	I <sub>F</sub> =5mA
Reverse Current	I <sub>R</sub>	---	---	10	μA	V <sub>R</sub> =5V

### Note:

1. Point sources of the amount of radiation per unit time in a given direction within the unit solid Angle radiated energy.
2. 1/2 is the off-axis angle at which the Radiant Intensity is half the axial Radiant Intensity.
3. The I<sub>e</sub> guarantee should be added ±15% tolerance.

## Recommended Wave Soldering Profile

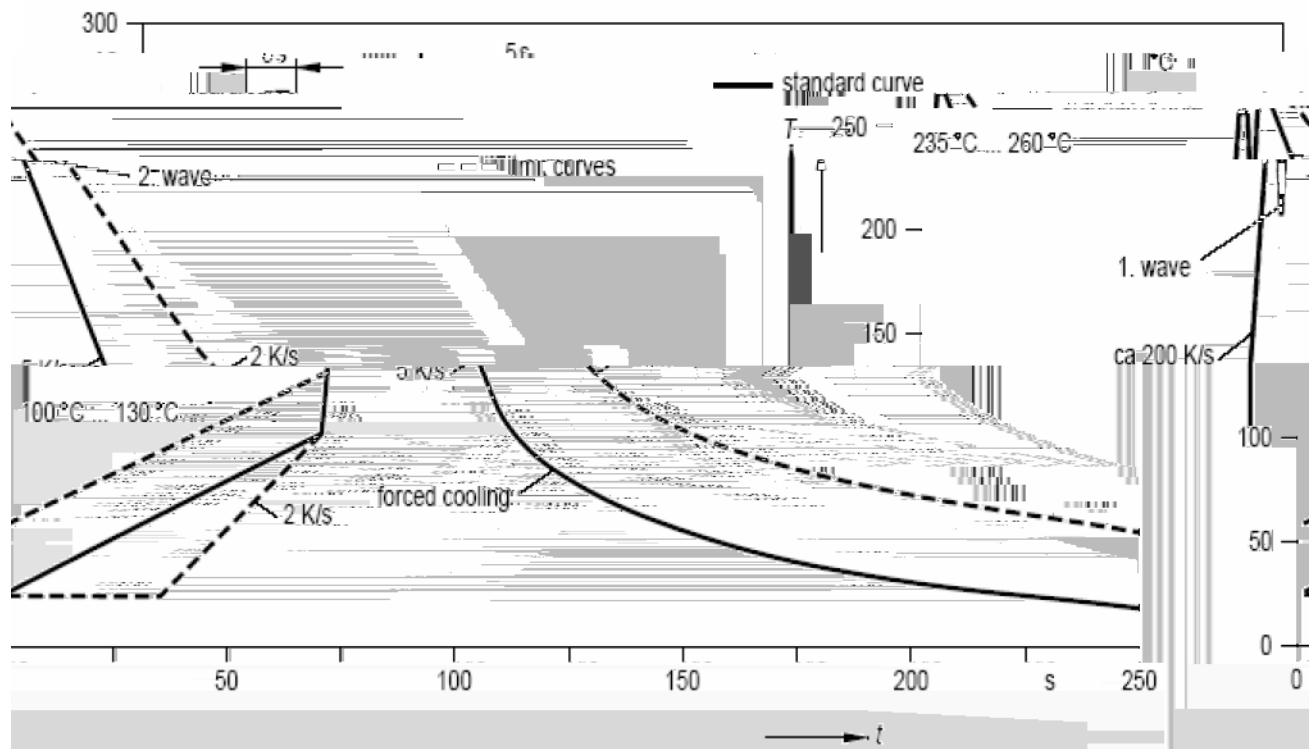

## Infrared Emitting Diode Specification

●Commodity: Infrared emitting diode

●Radiant Intensity Bin Limits (IF=5mA)

BIN CODE	Min.(mW/sr)	Max. (mW/sr)
E2	0.44	0.53
E3	0.53	0.64
E4	0.64	0.77
E5	0.77	0.92
E6	0.92	1.10
E7	1.10	1.30

**NOTE:** The Ie guarantee should be added  $\pm 15\%$  tolerance.









## PACKAGE

<b>LIGHT</b> Light Electronics CO., LTD.	
TYPE NO : _____	LOT NO : _____
QUANTITY : _____	
BI N _____	
DATE CODE : _____	
REMARKS : _____	

Bag minimum volume (pcs / Bag)	Bag volume (pcs / Bag)	Inner box volume (Bag / box)	Outer carton volume (Box / Carton)
500	1000	10	4